

FORESPAR[®]

Leisure Furl[®] Passagemaker[™]

Aft Drive In-Boom Furling System

Installation Manual



Forespar[®] Products Corp.

949-858-8820

[Email: leisurefurl@forespar.com](mailto:leisurefurl@forespar.com)

www.forespar.com

Table of Contents

Page
No.

3. Overview & Disclaimer
4. Components packing list
5. Tools required
6. Aft drive assembly
7. Reef-Lok™ assembly
8. Pre-installation – sail track dimensions
9. Pre-installation instructions
- 10-11. Installation – sail base track & slugs
12. Installation – luff foil
13. Installation – flexible sail feeder
14. Installation – limit line assembly
- 15-16. Installation – drive components
17. Installation - boom and mandrel
18. Deck layout, Initial check
19. Sail fitting, adjusting flex feeder limit line
20. Tack & clew adjustment
21. Lug & bail fittings
22. Installation checklist
23. ***IMPORTANT NOTICE TO INSTALLERS & OWNERS***
24. Serial number, installation notes

Overview

The **Leisure Furl® Passagemaker™** in-boom furling system, available in three sizes, is a combination of two proven Leisure Furl systems. The mast mounted Reef-Lok™ includes the winch handle manual backup common to the hydraulic and electric Leisure Furl systems. The aluminum boom shell assemblies, stainless steel front ends, aft spigot, luff tracks, universals and gooseneck assemblies are used in the Leisure Furl Offshore™ systems.

The following pages cover the installation of the Leisure Furl Passagemaker boom and components. Please read this installation manual thoroughly and ensure you have a complete understanding of all the steps prior to beginning the installation process. If there are questions, please contact Forespar® for clarification. Every effort is made to simplify the learning process, but some of the drawings in this manual may be generic in nature and not an exact representation of the actual components. However, this won't influence the installation process.

This installation manual is a guideline which is meant to aid the installer in accomplishing a proper and structurally sound installation. When the Passagemaker boom system is assembled correctly, it will operate correctly. It is the responsibility of the installation team to ensure the fit and finish is in-keeping with the fine yacht upon which it is installed.

An experienced rigger should have a thorough knowledge and understanding of general rigging installation principles. These guidelines should be read in conjunction with such other principles. Such principles shall be deemed to supplement these guidelines.

For Passagemaker™ boom installations on catamarans, also see "Leisure Furl Technical Bulletin 9-25-19 Rev. B" for installation issues specifically for catamarans.

Installation of the Leisure Furl® system is entirely at your own risk. We accept no liability for personal injury or property damage resulting from faulty installation. Nor do we accept warranty claims resulting from faulty installation. Do not install a Leisure Furl system except on the boat for which it was specifically designed and manufactured.

Painted Leisure Furl booms must never be left wrapped in plastic. This can cause the paint finish to blister, and is not covered by the Warranty on Finishes and Coatings. Immediate unpacking upon delivery is required.

Boom vang & topping lifts

In-boom furling systems require both a Forespar® Yacht Rod rigid boom vang and a traditional boom topping lift for safety and ease of sail trimming. If a rigid boom vang absolutely cannot be fitted due to space limitations, see "Leisure Furl Technical Bulletin 2-25-20 Rev. A" for installations without a vang.

When furling or reefing, the boom should be adjusted to the required 87° angle and held at that angle with the support of the boom vang during the furling process. In heavy weather the boom topping lift should be used to arrest the motion of the boom during furling.

When the boat is moored, a boom topping lift will extend the life of your boom vang no matter what type (spring, pneumatic or hydraulic).

Components Packing List

Leisure Furl® boom assembly:

Boom shell assembly

Mandrel assembly

Furling line (installed on drum):

18/6 – 85' [26 m] x 5/16" [8mm] double braid Dyneema core

19/6 – 100' [30.5 m] x 3/8" [10mm] double braid Dyneema core

20/7 – 110' [33.5 m] x 7/16" [11mm] double braid Dyneema core

Sail cover (installed)

Vang lug, dog screws

Mainsheet bails, dog screws

Gooseneck toggle, bolts, Nylok nuts, bushings, washers

*Inner bearing gooseneck fitting with hat bearing, bolts

*Winch handle casting with hat bearing, bolts

*Drive shaft assembly

*Universal coupling, drive pin, retaining ring

*Spacer washers for universal installation

*Vang bracket & swivel (if ordered)

*Feeder assembly – flex feeder, leaf spring, prefeeder, fillister screws

*Tracks:

Base track extrusions, slugs, bolts, alignment pins

Luff foil tracks, retainer clips

*Top chafe cap, screws

*Base track bottom bracket, bolts

*Seating compound kit

Lashing kit

*Luff tape (usually shipped directly to sailmaker)

*Installation Manual

Owner's Manual

McLube SailKote

* indicates items that may be "pre-shipped" to rigger prior to shipment of boom

Tools Required

Pencil

Paper

Hacksaw, including spare blade

Scraper

Soft hammer

Allen key set

Hole saws – 1-1/4" [32mm], 1-1/2" [38mm]

Electric drill, 1/2" chuck

Electric grinder, 4"

Masking tape

Drill bits – #26, 3/16", #7, 13/64", 1/4", 5/16", 3/8", 25/64"

Taps – #10-24, 1/4"-20, 5/16"-18, 3/8"-16

Tap wrench

Anti-corrosion compound - Lanocote™, TEF45™ or similar

Loctite

Center punch

Mixing stick

Sandpaper, 180 or 220 grit

Deburring tool

Cutting knife, long blade

Winch handle

Tape measure

Long Mylar straightedge (to wrap around mast)

Round file

Boatswain's chair

Aft Drive Assembly

The heart of the Leisure Furl® Passagemaker™ is the aft drive assembly. This consists of a furling drum, attached to the aft end of the mandrel by means of a mechanically fastened internal sleeve. The aft end of the drum/mandrel assembly is supported by the aft spigot. The aft sheave directs the furling line onto the drum.

Prior to moving the boom with the assembled mandrel, ensure the forward end of the mandrel is properly supported.

Passagemaker™ booms are shipped fully assembled, with the furling line pre-wrapped around the drum. **At least three wraps of the furling line should remain on the spool when the sail is fully furled.**

The drum is free to slide along the spigot. As the aft end of the boom is lowered or raised, the gap between the aft end of the drum and the aft spigot plate increases or decreases. When hanging the boom on the mast, lowering the aft end will cause the drum/mandrel to slide forward on the spigot.

WARNING — it is possible for the furling mandrel to slide off the aft spigot if the boom is lowered to the deck, resulting in possible damage to the mast area and universal if raised into position without realignment. Ensure the mandrel is aligned with the spigot before lifting up to the desired height.

Below are exploded and assembled views of the aft drive assembly.

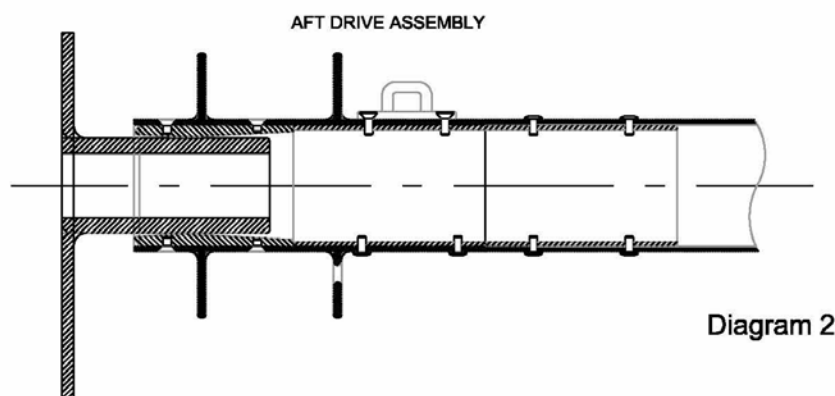
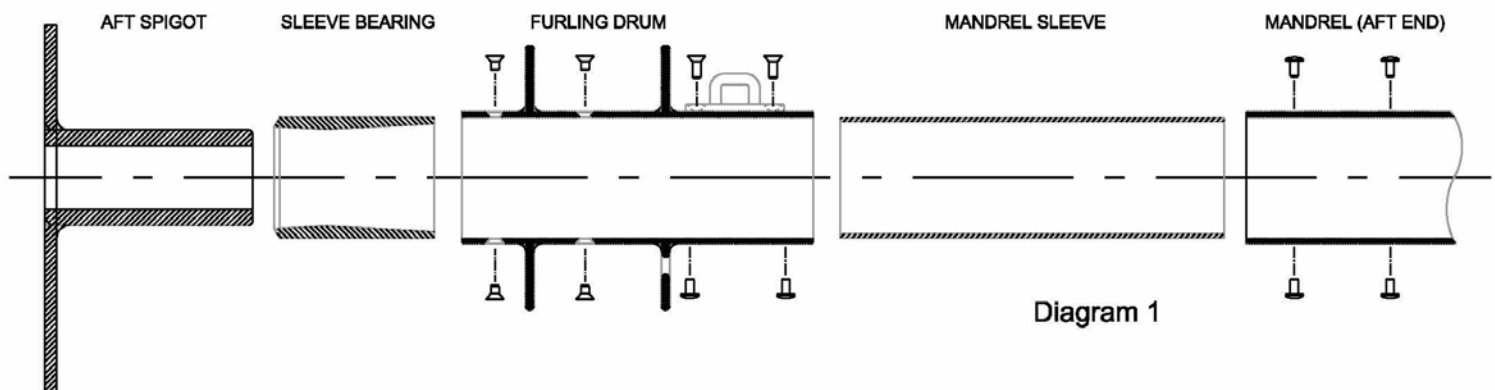

Mast Mounted Reef-Lok™ and Manual Winch Handle Backup

The Reef-Lok™ is mounted behind the mast. The lock pin has two positions: up (engaged), and down (disengaged). A socket on the front face of the mast allows a winch handle to be used as a manual backup for furling.



Diagram 3

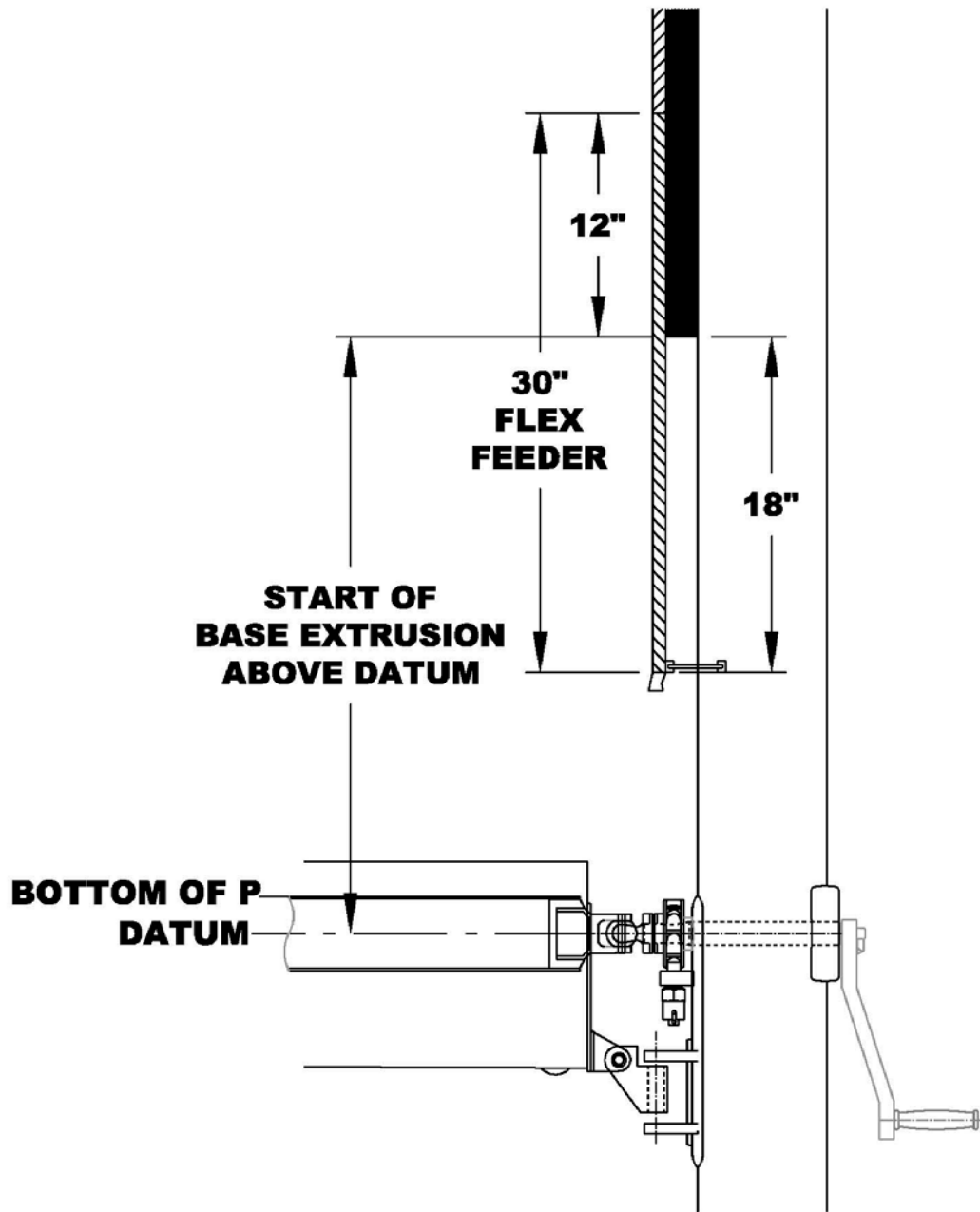

Diagram 4

System size	Shaft size	Shaft hole offset to starboard	Mandrel size	Datum below bottom of P	Start of base extrusion above datum	Flexible feeder extension
18/6	1" [25mm]	1/4" [6mm]	4" [102mm]	2" [51mm]	32" [813mm]	18" [457mm]
19/6	1" [25mm]	1/4" [6mm]	4-1/8" [105mm]	2-1/16" [52mm]	32" [813mm]	18" [457mm]
20/7	1-1/4" [32mm]	5/16" [8mm]	4-1/8" [105mm]	2-1/16" [52mm]	34" [864mm]	18" [457mm]

Pre-Installation Instructions

There are three stages to fitting the Leisure Furl® system:

1. Fitting the sail track
2. Fitting the mast components
3. Fitting the boom and mandrel

Each stage is broken into separate step-by-step instructions on the following pages, which will guide you through the installation.

Before removing or installing any components, check this manual to establish if any special instructions have been given for this job.

If the sail track is fitted while the mast is in place, it may require two people, one to assist while the other fits the track in place. While the track is being fitted in position, the other person can be preparing the mast for later work.

For purposes of fitting the sail track, the aft face of the mast from the bottom of the luff extrusion to near the deck should be clear from obstructions or sharp edges. Any hardware inside of this area may need to be repositioned.

Hold the fittings in their approximate position to determine if repositioning of any fittings is required. Consider the side of the boom as it articulates from side to side. If the mast has a spinnaker track down its front face, the track will need to be cut above the winch handle socket.

For installation to an existing vessel, there are several points to consider. If the gooseneck is positioned in the same location as it was previously, the bottom of P will rise up to the top of the furling mandrel location as can be seen from Diagram 4.

A second consideration is the boom height in the cockpit. The Passagemaker™ boom requires an 87° tack angle, so the boom may be higher over the cockpit relative to a conventional boom with a larger tack angle.

Thirdly, consideration has to be given to the backstay if clearance is getting marginal. This should have been considered when ordering the boom, but if the boom ends up higher at the forward end and on a greater upward angle it could be a problem.

Note: With a rigid vang, check to ensure the stroke is enough to allow repositioning if the boom is to be lowered or raised from the current position. Moving the vang lug along the boom may not always be a good option, as the angles may become unrealistic.

For installation to a new vessel, the positioning of the gooseneck will be determined as per the information on page 10. It is the Leisure Furl® agent's responsibility to determine the final "P" measurement.

Note that the Passagemaker™ boom may have greater depth than the existing boom, so this must be taken into account for maintaining sufficient clearance above dodgers, biminis, etc.

Installation Instructions – Fitting the sail base track & track slugs

1. After confirming the gooseneck position, make a reference mark for the position datum which is the center of the drive shaft.

Note: The datum position is the reference for all measurements.

2. **The base track extrusion and luff foil must be installed before any other fittings are attached to the aft face of the mast, since the bottom 6’ luff foil must be able to slide onto the base track without interference.**
3. Using the “Start of base extrusion above datum” dimension from Diagram 4 for the appropriate system, mark a position above datum for the bottom of the base track. Refer to Diagram 5 and mark the location of the top of the base track. The top piece of base track is to be the only “cut length”, so the base track assembly spans the distance between the top and bottom reference marks. There must be .020” [0.5mm] gaps (thickness of two business cards) between each length of base track. These gaps allow for modest mast bend without crushing the ends of the base tracks.
4. Cut the top piece of base track to the required length. Drill & tap for the two #10-24 x ½” screws for the top cap, and attach the top cap to the base track. Ensure that the top cap won’t prevent the top of the base track from contacting the mast, and grind if necessary.
5. Insert 18 or more mounting slugs into the mast luff slot, raise to a convenient waist level and place a piece of masking tape across slot to hold up the slugs.
6. Hold the cut length of base track that has the top cap attached against the back of the mast and insert a provided ¼-20 flat head machine screw (FHMS) through the top hole in the base track and into the topmost slug, using Lanocote™ or TEF45™.
7. While pushing the base track upward as you work, engage a slug for each hole in the base track.

SYSTEM SERIES	SAIL TRACK TOP CAP REFERENCE DIMENSION
18/6	10.5” [267mm]
19/6	11.5” [292mm]
20/7	12.0” [305mm]

Note: If the main halyard sheave extends at least 2” [50mm] from the aft face of the mast such that the halyard lead is nearly vertical, the base track can go all the way up to the black band (full hoist).

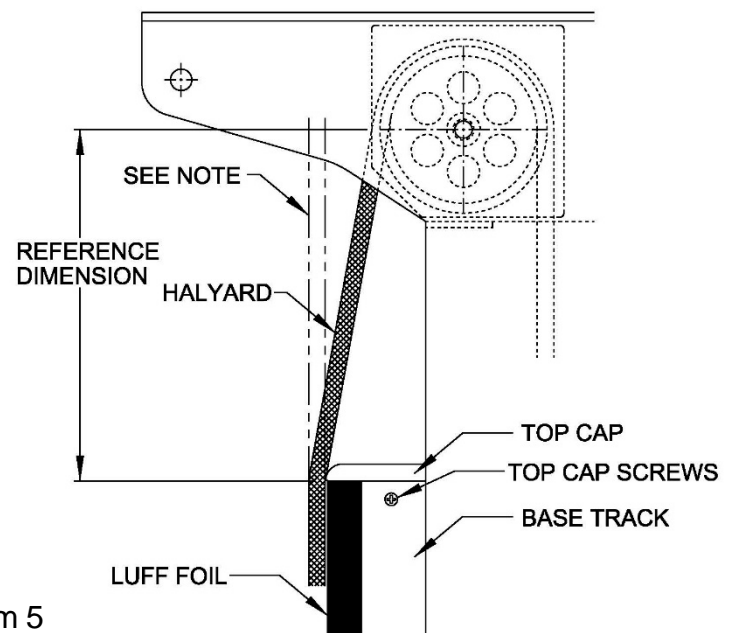

Diagram 5

8. When the first set of slugs are installed, send the first base section to the person at the masthead for tightening in place while the second track base is being prepared below. Position the top of this first “cut length” section of base extrusion at the reference mark at the top of the mast.
9. Alternately, if you are working alone, once you have raised this first section to the top of the mast and fixed it in place, you can install successive sections pushing them up the mast as you progress. The base track weighs about 1 lb/ft [1.5 kg/m].
10. Introduce more slugs into the mast luff slot as needed. Install alignment roll pins in the top end of each base track section using Lanocote™ or TEF45™, and progressively install track sections and tighten the screws. Ensure that there is a .020” [0.5mm] gap (thickness of two business cards) between all sections and make sure each joint is well aligned and the roll pins are engaged in both sections. The bottom of the last base extrusion has holes drilled and tapped for securing the flex feeder piece.
11. The stainless steel L-shaped bracket fits against the bottom of the base track. Install on the mast with the 2 supplied flathead bolts. In many cases, slugs may be used for this.

Installation Instructions – Fitting the luff foil

The aluminum luff foil system is 12” [305mm] shorter than the base extrusion system. The “cut length” of foil is the piece which goes at the top, and the cut end must be at the very top of the foil system. This placement ensures that the sail will never be in contact with a cut end of foil. Cut the top luff foil to the required length, slide it cut-end up to the top of the base extrusion and push a stainless steel retainer clip into the bottom (See Diagram 6).

The luff foil sections must have smooth and fair edges. Inspect all luff foil ends during installation and smooth as necessary using fine grit emery cloth.

Continue sliding 6’ lengths of foil onto the base extrusion, placing a stainless steel retainer clip into the bottom of each length. If required, tap the bottom of each luff foil in order to close the gap to the thickness of the retainer clip material. Use a hammer and wooden block so as to not damage the extrusion. The leg of the retainer clip that extends aft between the luff foil sections should be parallel to the end of the luff foil extrusion.

These retainer clips help hold the foil lengths in place during installation and establish a .020” [0.5mm] gap between each length of foil. The .020” gaps in the luff foil joints allow for modest mast bend without crushing the ends of the extrusions.

Ensure that the bottom end of the aluminum luff foil is 12” [305mm] above the bottom of the base extrusion. This is an important dimension to allow sufficient overlap of the flex feeder and the base extrusion.

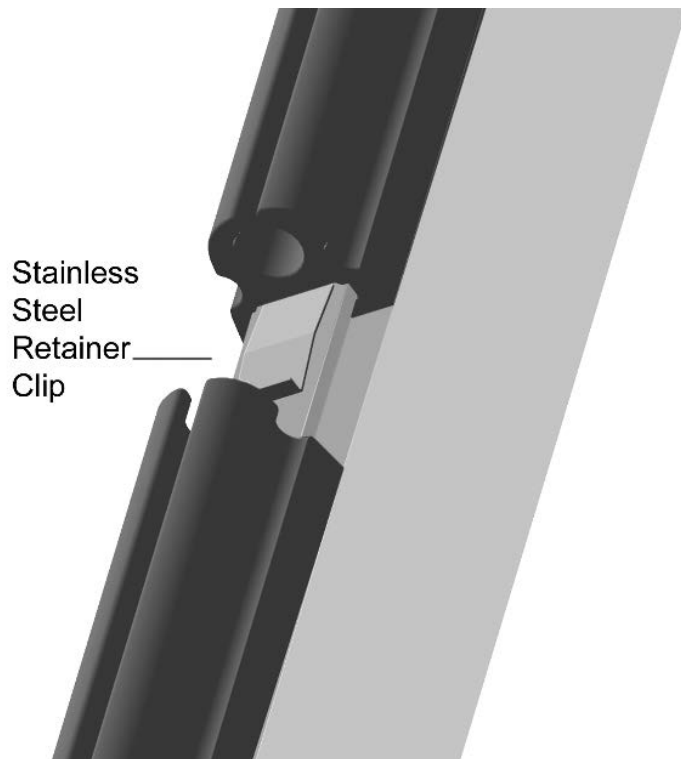

Diagram 6

Leisure Furl® Flex Feeder Installation

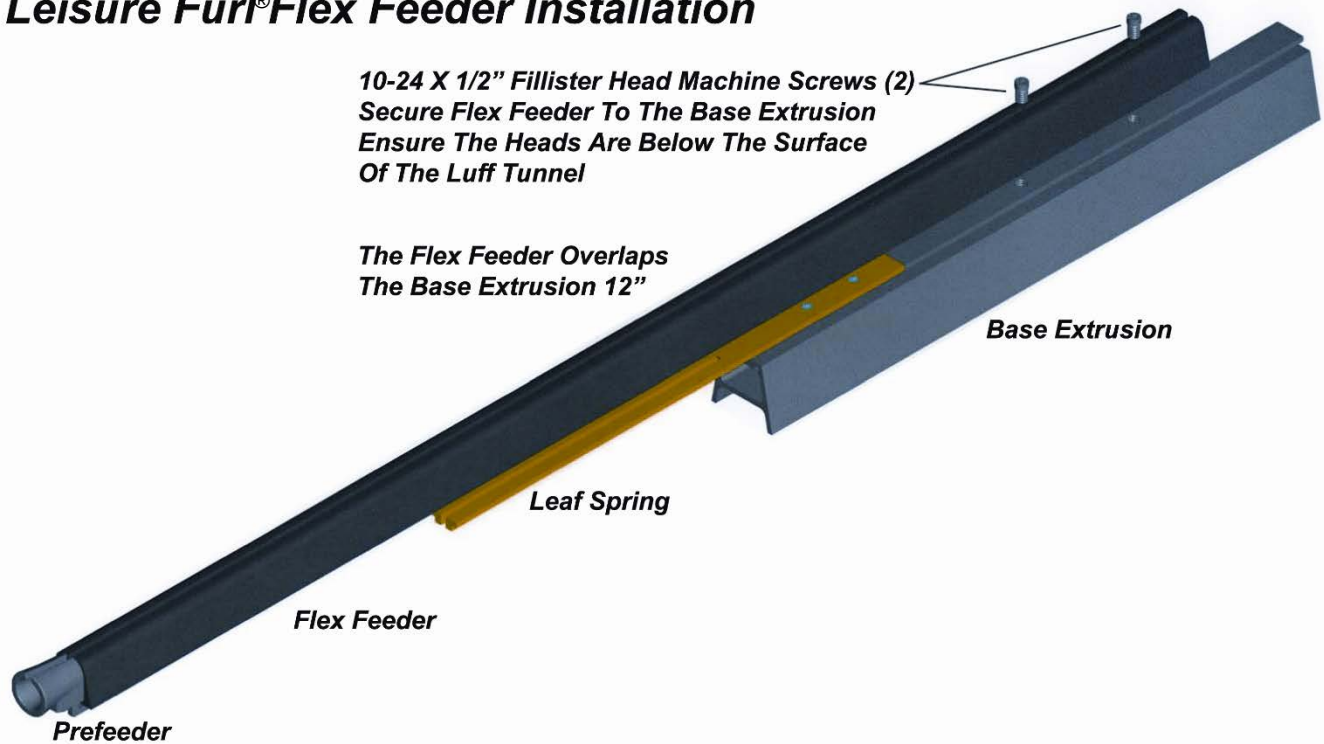

Diagram 7

INSTALLING THE 30" POLYMER FLEX FEEDER

Install the nylon leaf spring by threading the two provided #10-24 flat head machine screws into the pre-drilled holes at the bottom of the base track extrusion. Apply Loctite to screws to secure.

Now slide the 30" [762mm] polymer flex feeder onto the leaf spring and base track extrusion, butting it up against the bottom of the aluminum luff foil. Carefully use the flex feeder as a drill guide to mark the two fastener locations on the base extrusion. **DO NOT** drill the base extrusion through the flex feeder. This action could result in the holes in the flex feeder being elongated. Remove the flex feeder, drill using a #26 bit, and tap with a #10-24 UNC tap. Reassemble the flex feeder and secure with the two provided #10-24 x 1/2" fillister head machine screws using Loctite, per Diagram 7. Ensure that the screw heads are below the inside surface of the flex feeder.

Installation Instructions – Flexible feeder limit line fitting instructions

The limit line assembly consists of two stainless steel termination blocks and a fixed length of Spectra™ line which passes through the eye on the forward face of the luff prefeeder.

To install the limit line termination blocks on the mast, position the port and starboard blocks at an equal distance from the aft face of the mast and at the same height as the loop on the stainless steel prefeeder. **The limit line should be loose enough to allow the track to flex port and starboard but not aft.** With that in mind, the termination blocks should be installed on the mast sides as shown in Diagram 8.

The termination blocks are installed using the 1/4-20 FHMS provided - use a #7 drill, then tap. The knot in each end of the limit line must be pushed out of the termination block to expose the fastener hole. This allows marking of the mast for drilling and tapping, and access to install and tighten the screw. This may require flexing the track forward to install the second termination block. A piece of light line tied around the mast and luff track may be handy here to hold the track in the forward flexed position.

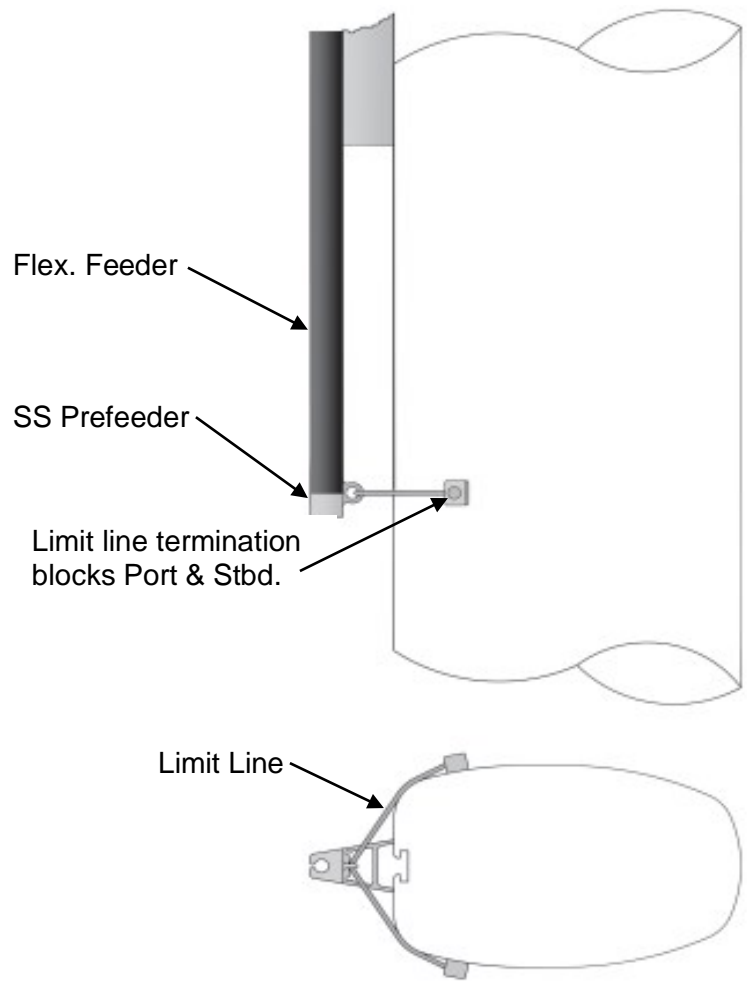

Diagram 8

Installation Instructions – Fitting the drive components

Find your previously marked datum position. Note: The datum position is the reference for all measurements. Wrap a Mylar or similar straight edge around the mast ensuring that the edges are parallel where they overlap. Tape the ends together to position securely.

Align the top or bottom edge of the straight edge with the datum position and draw neatly around to form a parallel edge at the datum position.

Mark the aft center position on the datum line and then measure evenly around both ways to find the center forward position on the front face of the mast. Next find the indicated distance to starboard from the table in Diagram 4 and mark on both the forward and aft face. Use a center punch to locate the centers of the drive shaft hole.

Dry fit the winch handle casting and inner bearing gooseneck fittings on the mast to ensure that they fit the profile neatly, per Diagram 9. It is important that the center of the winch handle casting contacts the mast. If either side touches the mast wall before the center, grind the affected area until the winch handle casting fits neatly in position.

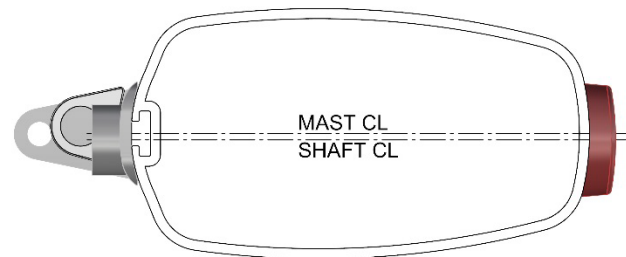

Diagram 9

Once fit closely, the inner bearing gooseneck fitting can be temporarily mounted on the mast to act as a guide for drilling the aft hole. Remove the plastic hat bearing, carefully align the center of the hole with your aft center mark and secure the fitting to the mast with the center two fasteners.

Drill the first drive shaft hole at the opposite end of the mast (forward or aft) of the internal wire conduit tube, if applicable. The forward hole is 1-1/2" [38mm] diameter for all systems. The aft hole is 1-1/4" [32mm] diameter for 18/6 & 19/6 systems, and 1-1/2" [38mm] diameter for 20/7 systems. Wedge the wiring tube over to one side through this first hole as you drill the opposing drive shaft hole. With a round file, deburr the edges of both holes.

Once the winch handle casting and inner bearing gooseneck fitting fit properly, prepare the mast for the seating compound. The seating compound is used to fill any voids between the fittings and the mast. It also acts as a corrosion barrier between the mast and the stainless inner bearing gooseneck fitting.

Place masking tape on the mast in the area where the inner bearing gooseneck fitting and the winch handle casting will sit. Be sure to mask outside the fittings an inch or two.

Place the inner bearing gooseneck fitting and winch handle casting back in their proper position on the mast. Mark the outer edge of both with a felt marker or pencil. Remove the fittings and cut the masking tape inside the perimeter marks. The area of mast now exposed will be covered with seating compound (see Diagram 10).



Diagram 10

The seating compound will require a sound base on the mast to adhere to, so sand the area and then clean with a solvent to remove any oils. Mask around the edges of the fittings themselves, and grease the shaft as compound may dry on this making it difficult to remove after fitting.

Mix the seating compound with hardener at approximately 2% by volume (use less in hot weather). Mix well until the hardener is blended with the compound. Apply the seating compound to the fittings, then position in place on the mast. Working time of the seating compound will vary depending on the temperature. Take caution in hot weather as the compound can go off within a minute. In cold weather it can take 10-15 minutes or longer.

Push both the inner bearing gooseneck fitting and winch handle casting very firmly against the mast. Install the PVC clamping tube assembly over the drive shaft (with the clamping tube against the inner bearing). Be sure to grease all components that will come in contact with the seating compound or some parts may become stuck. Tighten the clamping assembly. This compresses the fittings against the mast, and the seating compound will spill out from the edges. If there are areas that obviously require more compound, use the excess that has spilled out to fill them (if the weather is hot, be quick as you may not have a lot of time). Do not attempt to wipe the excess away.

Allow the compound to tack off, then carefully cut around the fittings with a sharp blade to remove excess compound before it fully cures. Do not leave it too long before cutting the excess away, as it will be a big job to clean up once it completely hardens.

After the compound has cured adequately, use the supplied 5/16" or 3/8" FHMS to fasten the inner bearing gooseneck fitting to the mast. If not already done, drill, tap and fasten the two center screws first so as not to misalign the fitting. **Use Loctite on all inner bearing gooseneck fasteners.** Tighten each screw incrementally in order to keep the fitting from binding on the shaft.

Insert a winch handle into the winch handle socket and rotate gently in both directions to free the drive. Disassemble the clamping assembly. Fasten the winch handle casting to the front of the mast with six provided 5/16" pan head machine screws using Loctite, beginning with the two center screws. Tighten each screw incrementally in order to keep the casting from binding on the shaft.

A bead of silicone or other sealant may be placed around the edges of the fittings to hide the seating compound.

In some instances it is possible for a wiring tube to rest against the drive shaft. This should not cause a problem unless it is pushing hard on the drive shaft. In this case, the rivets holding the tube above and below the shaft will need to be removed to reduce pressure on the tube. If possible, re-rivet the tube over to one side. No damage will result if the wiring tube rubs slightly on the shaft.

Installation Instructions - Fitting the boom and mandrel

With the furling mandrel positioned inside the boom shell, lift the boom into position on the boat. Attach the boom to the gooseneck using the supplied vertical bolt in the gooseneck swivel toggle. To fit the bolt, align the gooseneck spacers and toggle with the tangs on the mast. Once fitted in position, fasten the bolt in place with the washer and nut supplied.

If not already installed, insert the plastic hat bearing into the inner bearing gooseneck fitting. Slide the universal coupling/ratchet wheel onto the drive shaft until it touches the inner bearing. Clamp the universal coupling to the winch handle casting, ensuring that the winch handle receptacle is tight up against the casting. Mark the shaft where it exits the universal coupling. Remove the shaft, cut at the mark and deburr. Ensure that the shaft is cut squarely.

Reinstall the shaft through the winch handle casting, slide the provided spacer washer (see chart below) over the back of the shaft and install the universal coupling tightly against the inner bearing gooseneck fitting and clamp in place.

Verify that the shaft does not protrude beyond the universal coupling. Drill the universal drive pin hole using a 3/8" bit. The universal has a machined hole on one side. Drill into the drive shaft approx. 3/16" [5mm] deep through the hole in the universal.

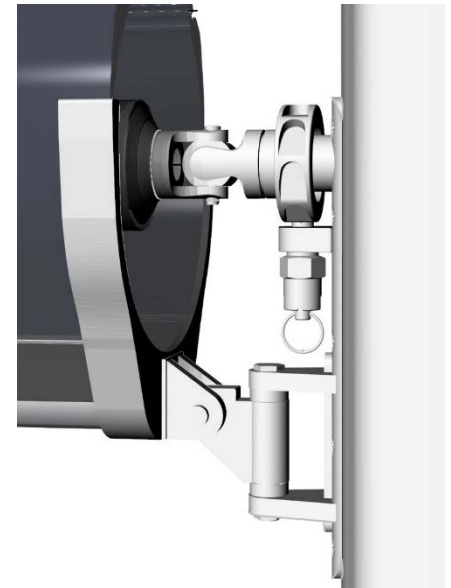

Diagram 11

A drill press is preferred when drilling through the shaft, but if using a hand drill make sure to drill at the proper angle so as to pass through the center of the shaft. Use a metal cutting compound to avoid work hardening the drive shaft. You may find it easier to drill through the shaft with a smaller drill bit first. If drilling through the shaft with a drill press, remove the shaft once center drilled. When reset up, ream the hole with the drill until the pin is a tap in fit. It must not be a drive fit. Deburr the edges of the hole, then refit the shaft to the mast.

Slide the universal coupling onto the drive shaft. The spacer washer should not be used for this final assembly. This allows for slight fore-and-aft play in the shaft. Align the drive pin holes and fit the drive pin, using Lanocote™ or similar to assist with future removal. Roll the spiral retaining ring into the groove to retain the drive pin. If the universal yoke has been detached from the mandrel, reattach it with the pins and "C" clips.

Thread the ratchet pin housing assembly into the ratchet lug using Loctite. The ratchet pin should align with the ratchet wheel throughout the wheel's fore-and-aft range of movement, and the pin should fully engage into the ratchet wheel when in the upward position. If the pin does not align properly, remove the universal coupling from the drive shaft and install spacer washers as necessary – see chart below.

Spacer Washers

<u>Part No.</u>	<u>ID</u>	<u>Usage</u>
866298	1"	Temporary spacer for 18/6 & 19/6 for drilling pin hole
866297	1-1/4"	Temporary spacer for 20/7 for drilling pin hole; can be used as spacer on fwd. end (all systems) or aft end (20/7) of drive shaft if necessary to align ratchet pin

Deck Layout

Consider the layout for leading the mainsail halyard and furling line aft. If the existing vang and topping lift lines terminate at the mast, it would be desirable to lead these aft as well. It is the rigger's responsibility to ensure that the deck hardware (mast base blocks, organizers and rope clutches) are suitable for high loads.

Lead the furling line down to a large, smooth running deck block directly below the boom gooseneck sheave. Lead the furling line aft beside the main halyard so they can be operated from the cockpit clutches.

It is essential that the mainsail remains visible during both hoist and furl, so position the electric winch operating switch and control lines in a position in the cockpit to allow this. Use of the existing rope clutches may determine the position for operation. The winch operating switch should be positioned to allow the operator the freedom to use both hands for managing the lines. Consider positioning the winch operating switch in the cockpit sole to allow foot operation.

Initial Check

Ensure the furling mandrel rotates freely.

Ensure the ratchet pin is engaging properly in the ratchet wheel.

Ensure the feeder is correctly aligned with the sail track, adjust to correct if necessary.

Ensure that boom is at the correct operating 87 degree angle – use the template below if desired.

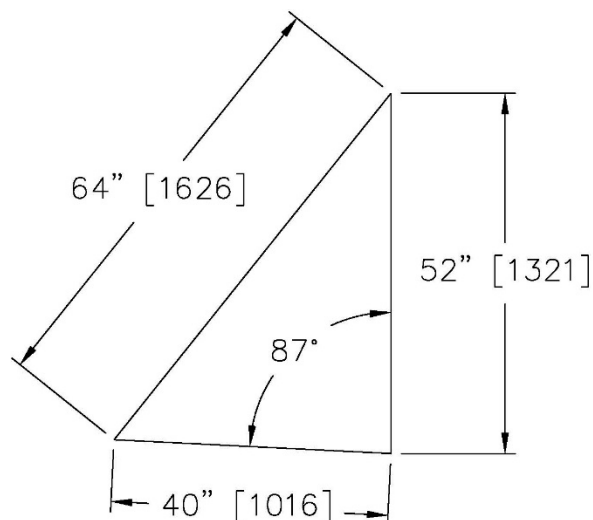

BOOM ANGLE TEMPLATE
-MARK MAST AT 52" (1321mm) ABOVE
MAST/BOOM INTERSECTION, & MARK
BOOM AT 40" (1016mm) AFT OF
INTERSECTION.
-POSITION BOOM SO THAT DISTANCE
BETWEEN MARKS IS 64" (1626mm).

Sail Fitting

1. With the sail laid on the port side of the boat, lift the foot up to the furling mandrel, then slide the foot boltrope into the track from either forward or aft.
2. Lash the mainsail tack to the tack padeye on the mandrel, with the luff boltrope aligned with the flex feeder.
3. Now lash the clew to the aft padeye on the mandrel – see Diagram 12, Adjustment C on next page. ***Do not pull the foot out tight***; leave fullness in the foot for efficient downwind sailing. The built-in sail controls will generate outhaul tension – see Owner’s Manual.
4. ***Using a separate lashing, lash the clew with a minimum of three wraps around the furling mandrel, pulling the clew down to within 1/2” [12mm] of the mandrel – see Diagram 12, Adjustment B on next page.***
5. The mainsail may be initially furled onto the mandrel in one of two ways. In calm winds, you can first hoist the sail directly off of the deck. Set the boom to the correct 87° angle for furling before the sail is hoisted. The furling line should be pre-wound on the mandrel spool, so once the sail is fully hoisted it can be furled into the boom by winching the furling line and tailing the halyard. Use the minimum amount of main halyard tailing tension to ensure a tight sail roll.
6. In windier conditions, it may be preferable to furl the sail directly onto the mandrel without hoisting it. Remove all but 5 turns of the furling line on the spool, and disengage the Reef-Lok™ pin. Using a winch handle inserted into the winch handle socket on the front of the drive shaft, roll the sail onto the port side of the mandrel by turning the handle clockwise looking aft. Keep light tension on the furling line while doing this. We recommend two people assist by pulling either the luff or leech to ensure that the bolt rope remains in the area between the boom edge and the mast while the sail is being furled.

The sail fitting is complete, however minor adjustments may need to be made. See Owner Manual’s for guidance. ***Apply McLube (provided) to the luff tape as needed to reduce the friction in the luff foil.***

Adjusting Flex Feeder Limit Line

The desired amount of flex for the flex feeder has to be determined by hoisting and furling the sail. The furling operation should be done several times, with eyes on the luff of the sail. Ensure that the 87° boom angle is correct, and then watch as the sail rolls into the boom. Furling should be checked at different angles to the wind, since this is the true test of the flexible feeder setup.

Once the termination blocks have been installed on the mast, the only way to control the amount of flex in the unsupported portion of the luff track is to change the length of the limit line. If less flex is deemed necessary, the line can be shortened. If a longer line is required for additional flex, Spectra™ line can be purchased from your local chandlery. Use a figure eight stopper knot in each end, then trim the ends as necessary.

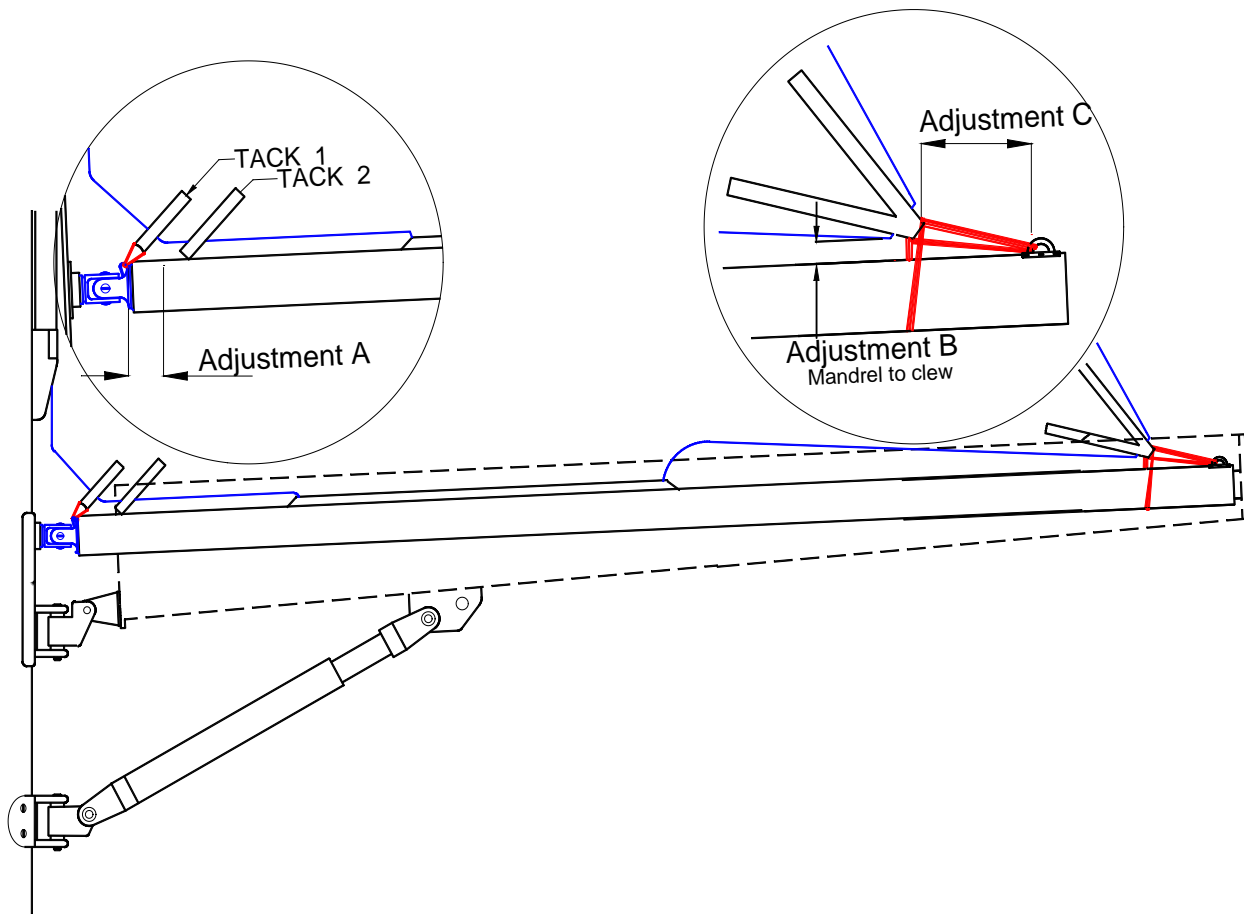

Diagram 12

IMPORTANT NOTE:

THE TACK LASHING LINE MUST BE MADE PRIOR TO THE CLEW LASHING. This establishes the tack location in regards to the luff foil and prevents aft loading. After the tack is lashed the clew can be lashed to the aft padeye, ensuring the foot of the sail is not pulled tight. The foot tension should be full and soft for full-hoist reaching. The clew lashing should be done separately, with several wraps around the mandrel to eliminate upward leech load on the clew padeye. Damage to the mandrel and the foot of the sail WILL result if this process is not followed.

Lug & Bail Fittings

All vang lugs and mainsheet bails are shipped loose. When fitting them in the boom track, they must be secured using the special dog set screws that have been provided.

IT IS VERY IMPORTANT THAT THE SAIL COVER BE PULLED TO THE FRONT OF THE BOOM PRIOR TO FASTENING THE VANG LUG AND SHEET BAILS. THIS WILL PREVENT DAMAGING THE SAIL COVER DURING THE DRILLING PROCESS.

1. Determine and mark the correct locations for the mainsheet bails and vang lug. The vang lug should be positioned such that the angle between the mast & boom is slightly less than 87° with the full weight of the boom & mainsail supported by the vang.
2. Starting with the forward-most fitting (usually the vang lug), slide the fitting into the track at the back of the boom, mark the location of the first hole then slide it out of the way. Do not attempt to drill the boom through the threaded hole in the bail or lug as the drill could damage the threads.
3. Drill the first hole $13/64"$ (18/6 & 19/6 systems) or $1/4"$ (20/7 system) through the top of the track.
4. Mark the location of the second hole, then slide the bail or lug out of the way and drill the second hole through the top of the track.
5. The drill bit used must be sharp so as not to leave a burr extending into the lower cavity of the boom. Use a deburring tool if necessary to remove any burrs which could possibly damage the sail cover.
6. Continue installing fittings in order from front to back. Note that if an optional boom light has been installed, the boom will arrive with the correct fittings slid into the boom track forward & aft of the light but not installed.
7. When all the holes have been drilled, use Loctite on the dog and the threads of each set screw and tighten. The dog set screws and Loctite must be used at every threaded fastening point of the bail or lug.
8. When tight, the set screws force the bail or lug tight against the underside of the track. The dogs lock into the drilled holes, which secures the fittings against the thrust loads, preventing them from sliding in the track.
9. **All bail & lug set screws must remain tight.** Checking these screws should be a part of the regular preventative maintenance inspections on your Leisure Furl® Passagemaker™ boom.

Only the dog portion of the set screw protrudes into the boom shell track wall.

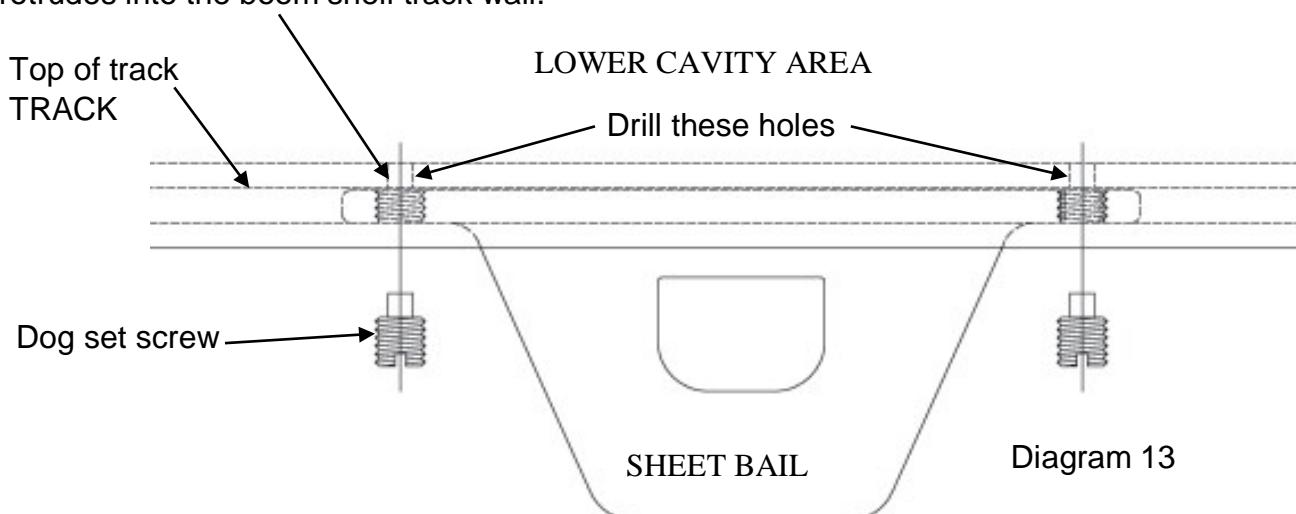

Checklist after installation

Review the following checklist for completeness. Fix any outstanding items to prevent damage to the system.

1. Ensure the mandrel/furling drum screw splice is secure.
2. Ensure the furling line leads fairly from the aft sheave box to the drum.
3. Ensure the mandrel spins freely.
4. Ensure that the Reef-Lok™ ratchet pin engages in the ratchet wheel throughout the wheel's range of fore-and-aft movement.
5. Ensure all machine screws have been treated with Loctite.
6. Ensure the sail track slugs are locked in place and tight in position.
7. Ensure the track ends are aligned and fair.
8. Ensure the flexible feeder and limit line is set up correctly (See Diagram 8).
9. Ensure the luff track top cap is in place and will not allow halyard chafe (Diagram 5).
10. Ensure there are no objects or sharp edges between the feeder and gooseneck for the sail to catch on.
11. Ensure the furling line is led aft in a manner to avoid friction where possible.
12. Ensure the boom angle to the mast is not limited by the vang or topping lift adjustment. If a spring/fixed vang is used, ensure the vang can support the boom weight.
The 87° angle to the mast is important.
13. Ensure the drive shaft does not protrude through the back face of the universal drive coupling. ***Ask if in doubt, this is extremely important.***
14. Wash the boat off thoroughly as metal shavings and filings could be caught in deck lines or may rust on the deck.

IMPORTANT NOTICE TO OWNERS AND INSTALLERS

- **Ensure there are a minimum of 3 wraps of the clew lashing around the mandrel at initial setup and each time the sail is reinstalled.**
- **Do not raise the boom with the topping lift or vang more than 3 feet [0.9m] from the normal operating angle, as the mandrel will bottom out on the boom end plate and cause damage. If it is essential to do this, the mandrel must be disconnected from the universal.**
- **If the boom is dropped down to the deck for any reason, ensure that the mandrel has not dropped off the aft end spigot before raising the boom again with the vang or topping lift.**
- **If it is necessary to furl downwind, pull the boom in to 45 degrees before commencement. This decreases the load in the sail, gets the sail off the shrouds and spreaders and increases the efficiency of the universal.**
- **If a topping lift only is being used to support the boom, tie a knot in the topping lift line aft of the rope clutch or cleat to ensure that if someone accidentally releases the topping lift cleat the boom doesn't crash down and cause damage or injury.**
- **Ensure all track joints are smooth and radiused. The track entrance from the sail prefeeder is particularly important. See Diagram 7. You can slide a short piece of luff tape through the luff track to check for smoothness.**
- **Ensure that there is nothing on the mast in the area where the sail rolls that could possibly cause sail chafe. This could include fittings around the side of the mast and trysail tracks.**
- **The maximum furling line diameter for an 18/6 system is 5/16" [8mm], and 3/8" [10mm] for a 19/6 or 20/7 system.**

Serial number

Forespar® keeps a file on all Leisure Furl® systems based on the 6 digit serial number. The serial number is located on the aft inside bulkhead at the back of the LF boom. Please record it here for future reference:

Serial Number _____

Your Installation Notes