



**FORESPAR<sup>®</sup>**  
**LEISURE FURL<sup>™</sup>**

**SAILMAKERS INSTRUCTIONS**  
**WEBSITE VERSION**

**CONTACT FORESPAR<sup>®</sup>**  
**FOR A DRAWING AND**  
**VESSEL-SPECIFIC**  
**DIMENSIONAL DATA**  
*(ITEMS A - K ON PAGE 2)*



**SPECIAL NOTE TO SAILMAKERS:**

***PLEASE READ THESE INSTRUCTIONS CAREFULLY  
PRIOR TO BUILDING OR REPAIRING A LEISURE FURL SAIL.***

*Leisure Furl mainsails are unique in design, and there are several areas where the information contained in these instructions must be followed. Foot design, head design, plying, luff tape and batten pocket placement are but a few items where straying from design specifications can result in a sail that does not perform as necessary. These instructions are intended as a guide for building the Leisure furl mainsail.*

*The sailmaker is responsible for the structural integrity of the sail.*

***Forespar Products Corp.***

*22322 Gilberto  
Rancho Santa Margarita, CA USA  
92688*

*Email alanm@forespar.com*

*Phone 949-858-8820*

*Fax 949-858-0505*

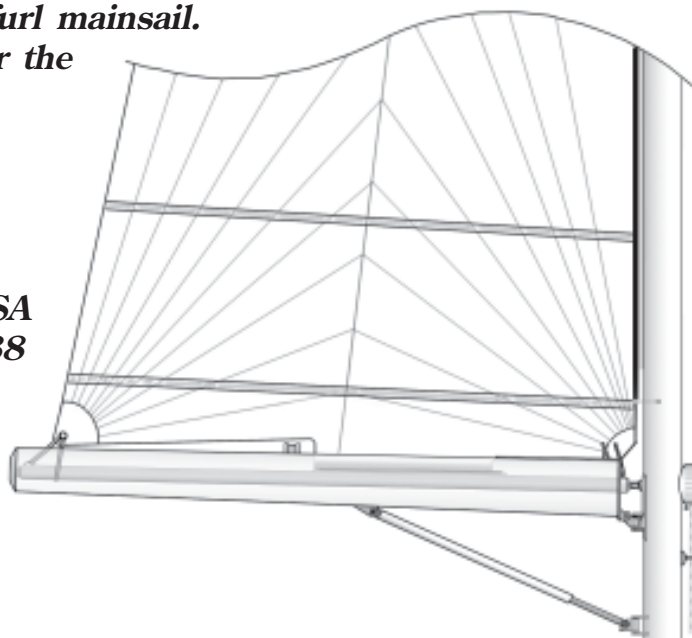

*December 2, 2015*

## *Leisure furl* - SAILMAKING...see sheet 5

- A. Tack angle taking a line between tack and head, and tack and clew -
- B. Height above foot, to center of bottom batten -
- C. Height above foot, cut back begins -
- D. Cut back -
- E. Foot bolt rope size -
- F. Length from luff, the foot bolt rope begins -
- G. Length from luff, the foot bolt rope finishes -
- H. Length of foot -
- I. Length from luff, to centerline of support bracket -
- J. Sail cut up to clear support bracket -
- K. Foot round -
- L. ***Areas of leach (shown as shading) to be two and three plied using the same weight of cloth as that of the sail***
- M. Tack Detail.....see sheet 5
- N. Batten details
  - Inner ends.....See sheets 7,8 & 9
  - Batten placement.....Fit lower batten to port, and all others to starboard
  - Batten stiffeners.....See sheet 6
  - Batten angles.....See sheet 4
  - Middle batten.....See sheet 4
- O. Luff length, if not indicated, confirm with Forespar®
- P. The outer end of the batten must be flush with leach and attached in a manner so as not to cause bulk
- Q. Tack patches, these should be kept to a minimum
- R. Leach cord cleats to be small (no greater than 1") and fitted to the port side of the sail

## *Leisure furl* - SAILMAKING...continued

- S. Spare luff tape and batten end kits are available from Forespar® ...see below
- T. Luff round - to be no greater than 25% more than the mast prebend, example, with mast prebend of 4" maximum luff round is 5". Maximum luff round is at mid luff height. At 25% luff length, luff round will be 90% of maximum. At 75% of luff length, luff round will be 50% of maximum. Use seam shape to compensate.

If the mast is set up very straight, use a maximum luff round of .5% of luff length, example with an 80' luff, actual luff round disregarding seam shape is 5".

- U. Clew detail

### NOTES:

Leisure furl does not allow for the use of cringles or metal fittings anywhere on the sail unless indicated. Cringles especially, are likely to catch the top lip of the boom and tear the sail.

It is important to leave 3" of bolt rope exposed at the bottom of the luff tape to allow for shrinkage.

Measurement 'l' on the sailmaking instructions gives support bracket position. Avoid a batten finishing right at this point. It needs to be at least 3" forward or aft of this position so adjust batten height accordingly.

**SMALL LUFF TAPE**  
[Suitable for Coastal & 19/6 models]

Call Forespar® for price

**LARGE LUFF TAPE**  
[Suitable for models 20/7 - 25/8OS]

Call Forespar® for price

***Forespar Products Corp.***

**22322 Gilberto**

**Rancho Santa Margarita, CA U.S.A. 92688**

**Phone 949-858-8820**

**Fax 949-858-0505**

**Email [alanm@forespar.com](mailto:alanm@forespar.com)**

# Leisure furl - SAILMAKING

## NOTE:

**This plying method is required on all sails.**  
**The 2nd and 3rd plys must be the same weight cloth as that of the sail.**

## NOTE:

**The sail rolls onto the furling mandrel from the port side. Any U.V. protection should be on the port side of the sail.**

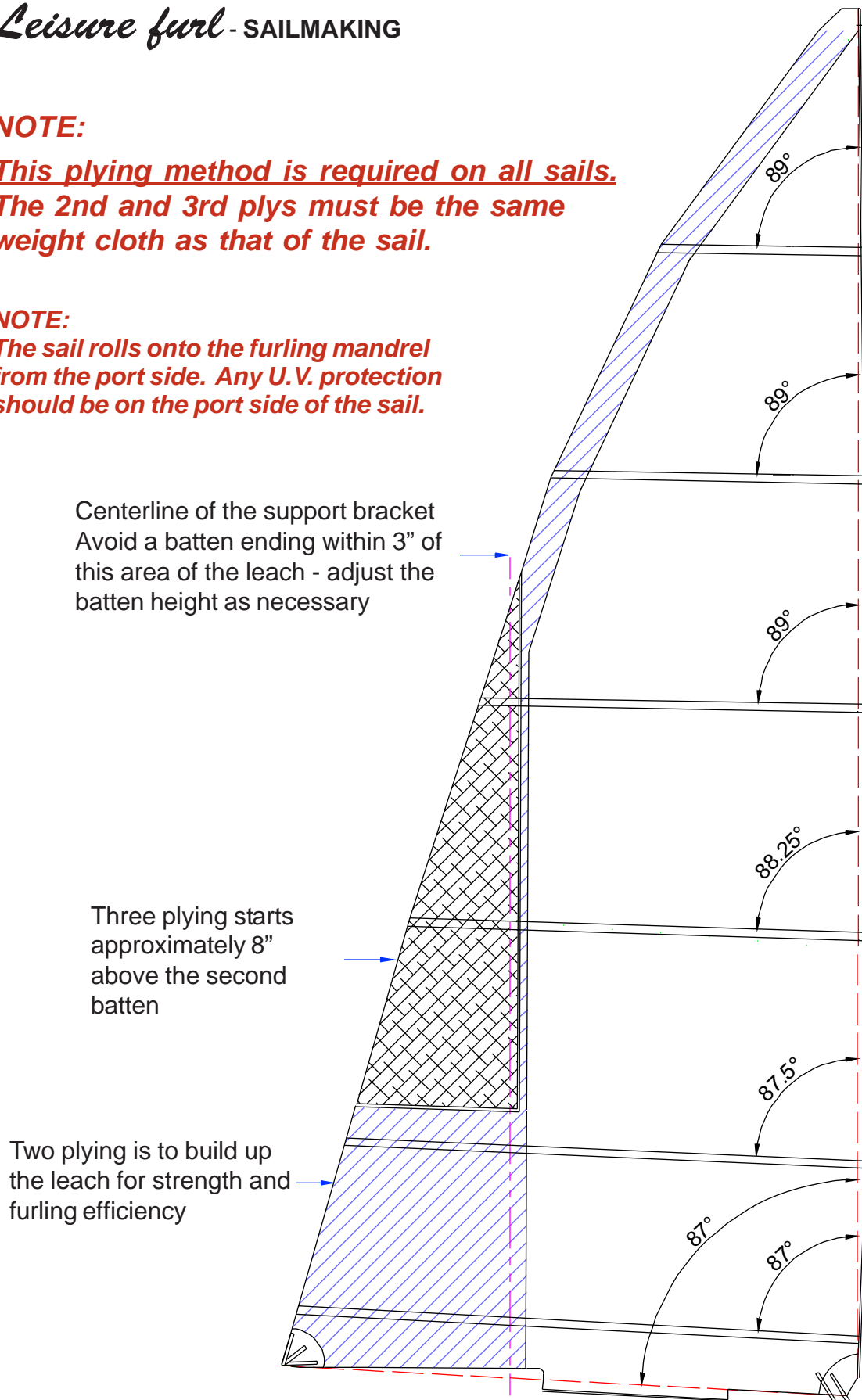

# Leisure furl - SAILMAKING

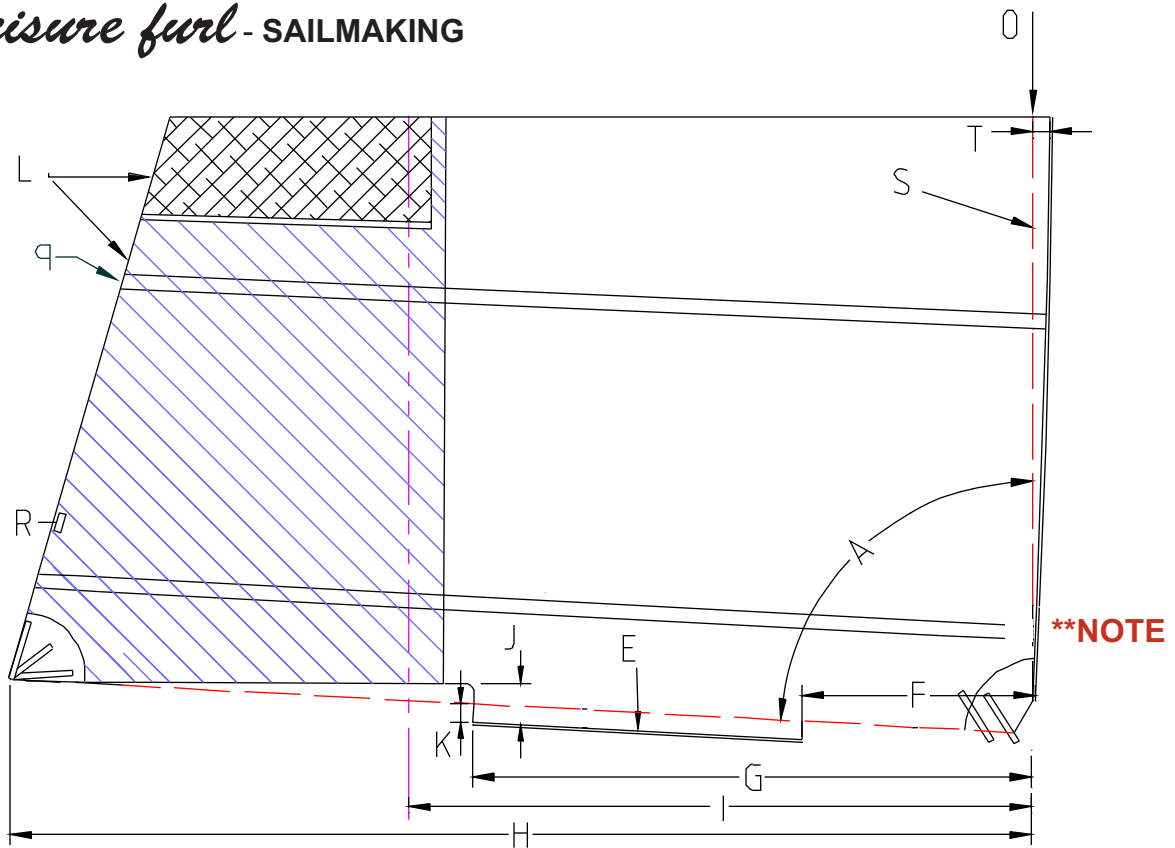

**\*\*The bottom batten should stop 50mm short of the luff**

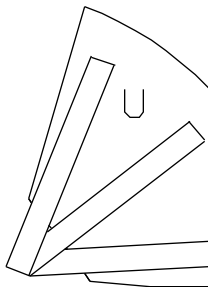

Clew to be cut diagonally, and the three webs intersect to take the load.

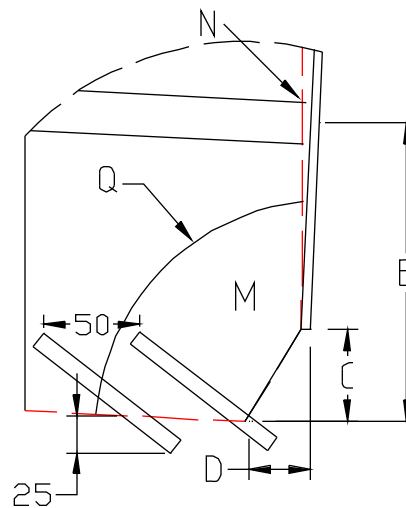

## Tack detail

There are two tack webs sewn into the sail at approx 45° & 50mm [2"] apart. The second web is for adjustment if required.

## *Leisure furl* - SAILMAKING

### Special points to consider with LEISURE FURL SAILS

1. The two and three plying of the leach is essential to gain the ability to furl efficiently. Also it could be worth considering a strip of UV, running the whole way up the leach. This will have some benefits from the furling point of view, and also it will avoid the need to pull the cover on all the time when cruising.
2. The luff tape supplied must be fitted directly to the sail without reinforcing tapes underneath, as they will seriously effect the furling of the sail. If it is felt essential to reinforce the luff because of the type of cloth or the construction of the sail one layer of 4oz Dacron 200mm wide or less can be used on only one side of the sail. This would only apply to sails for boats that are over 45 feet. Also, do not over tension (lengthwise) the luff tape when sewing to sail.
3. The luff round proportions specified are critical. Use seam shape to obtain desired draft. If preferred sail can be marginally flatter than average, but must not be “too” flat.
4. Indication of batten stiffness from Blue Streak range are as follows:  
30' to 38' boats use ocean/racer 3 for bottom three battens, ocean/racer 2 for next 2 and ocean/racer 1 for top batten. 38' to 45' use ocean/racer 4 for bottom three, ocean/racer 3 for next 2 and ocean/racer 2 for top batten. 45' to 55' use ocean/racer 5 for bottom 3, ocean/racer 4 for next 2 and ocean/racer for top batten. Please note that the size of the main and or roach need to be considered and it may require going up a size. **Do not notch the inner ends of the battens** taper as necessary to fit batten end assemblies.
5. Do not build twist into leach. A tight leach is essential for good furling. Where necessary, the leach can be opened by unloading boom or other option available.
6. Take great care to ensure batten angles are correct.
7. It is of the utmost importance that batten inner ends are exactly to the drawing supplied. The webbing inside the pocket needs to be tight weave polyester of approx. 1mm thick for the smaller boats and 1.2mm thick for the boats over 45'. The feeder guide at the boltrope must be on both sides of the sail and must be sewed substantially as indicated.

*Leisure furl* - SAILMAKING.....Hard batten End Detail  
[Suitable for boats to 35' LOA]

Step 1

Sew a semi circular patch to both sides of the sail.

Bolt rope tape

Step 2

Sew a conventional double batten pocket to starboard side of the sail. Leave the top layer open for a batten to exit at the front of sail.

75mm

Step 3

Step 4

Bolt on batten end.

Bolt through the batten

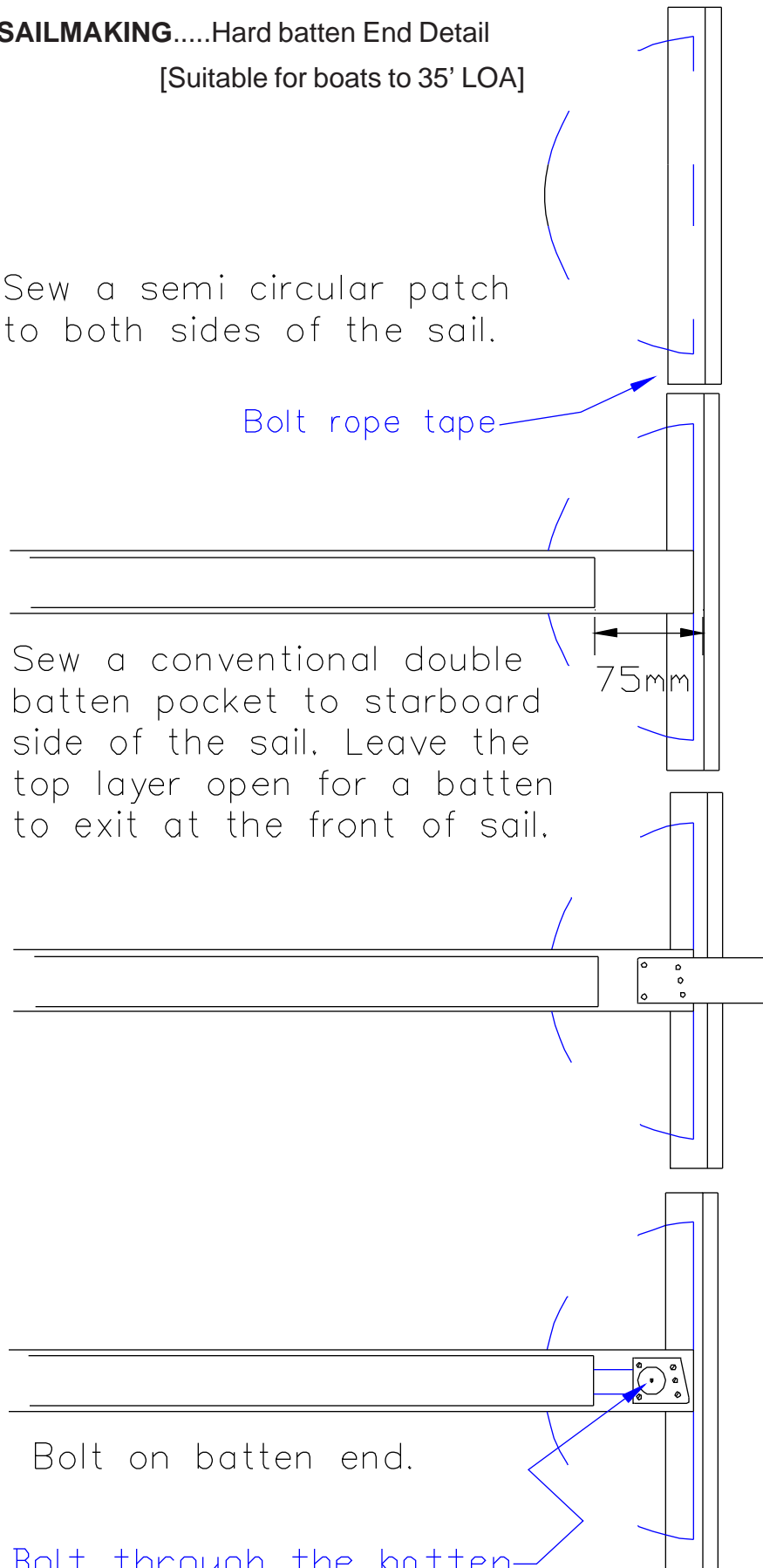

## *Leisure furl* - SAILMAKING

### FITTING INNER BATTEN ENDS

Do not fit plastic batten end to bottom batten (fitted to port side of sail). Use conventional webbing end terminating approximately 50mm from boltrope.

1. Cut semi-circular patches of approximately 6" radius from 12oz. Dacron or similar. Tuck the straight side of the semi-circle under the boltrope tape (leave a gap of 3/8" from the boltrope itself), and sew substantially to the sail.
2. Fit conventional double batten pocket on starboard side of sail, with bottom layer running right up to the boltrope, and the top layer terminating 75mm back and left open, so that the batten actually exits the pocket before entering the batten end.
3. Fit the sail batten ensuring that it is hard in to the end of the pocket. Drill through the center of the batten end right through the batten itself and bolt up tightly with the 20mm machine screws supplied. Use a penny washer on each side. Cut off any excess and file smooth. (Check all other screws are flush). **Note** it is most important that the batten ends are held securely at the outer end. If they were to come loose in strong winds they could damage the inner batten end.



# Leisure furl - SAILMAKING

Step one - Port side - fit two layers of patching  
 Note - bottom batten only is opposite side

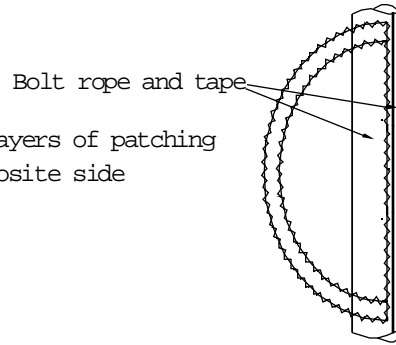

Step two - Stb. side - Make conventional double batten pocket  
 Join with a heavy web to take the batten thrust and fold back to form pocket

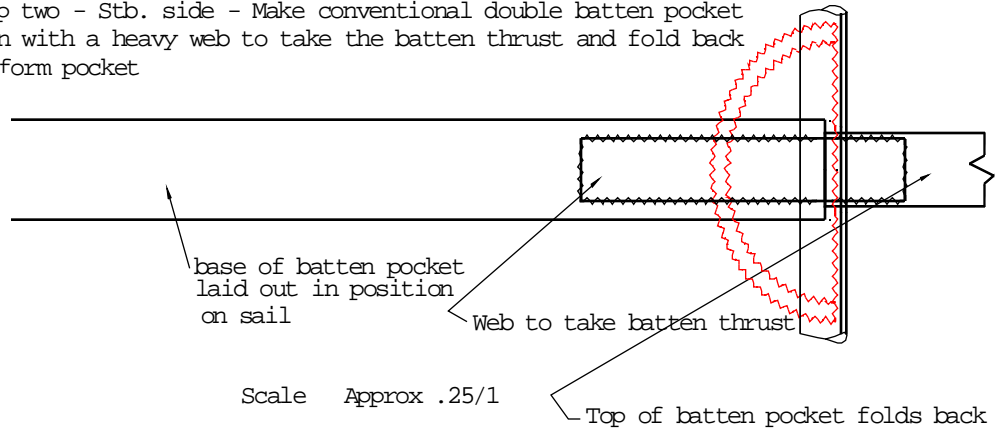

Step three - Sew batten pocket to sail

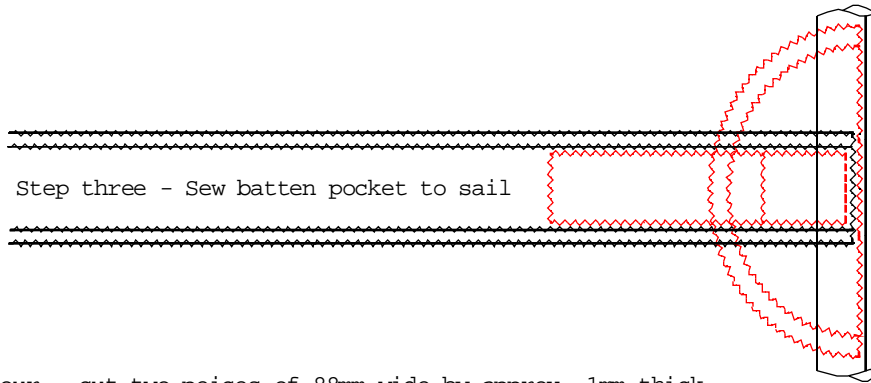

Step four - cut two peices of 88mm wide by approx. 1mm thick polyester webbing 125mm long. Fold front end back to form a curve and sew back onto itself to create a 2mm thick guide.

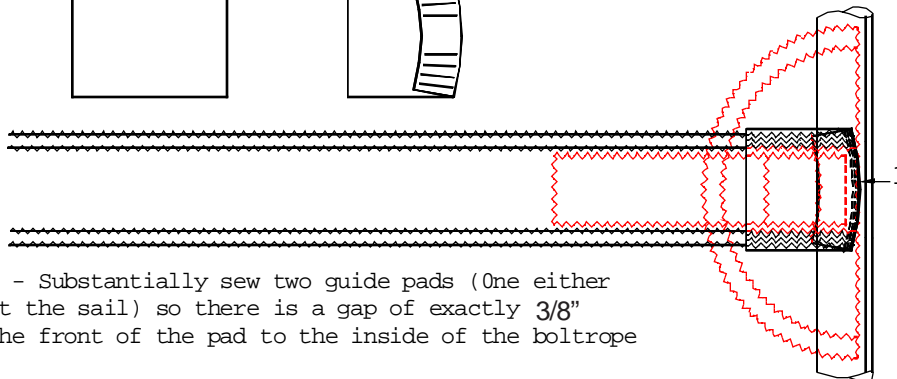
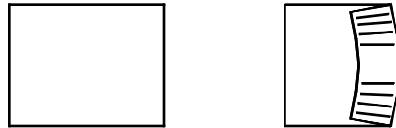

Step 5 - Substantially sew two guide pads (One either side of the sail) so there is a gap of exactly 3/8" from the front of the pad to the inside of the bolt rope

Scale approx. .25/1

# *Leisure furl* - SAILMAKING.....Soft batten End Detail

[Suitable for all boats]

## LEISURE FURL - IBE BATTEN DETAIL

IF UNSURE OF ANY DETAIL CONTACT A DEALER NEAREST TO YOU.

THESE INSTRUCTIONS ARE INTENDED AS A GUIDE ONLY. THE SAILMAKER REMAINS RESPONSIBLE FOR THE INTEGRITY OF THE SAIL.

- 1 SEW A STRIP OF LIGHT WEBBING  
- ALONG A BATTEN POCKET TAPE FOR EACH SIDE OF THE SAIL.

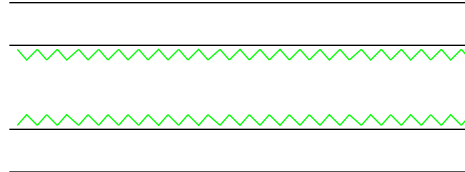

- 2 ATTACH THIS TO THE SAIL, LEAVING  
- APPROX 90mm OVER HANGING THE LUFF TAPE CENTRE LINE. SEW THE BATTEN POCKET TAPE TO THE SAIL AND TO THE LUFF TAPE AS SHOWN.

6oz DACRON TAPE OR SIMILAR

SAIL

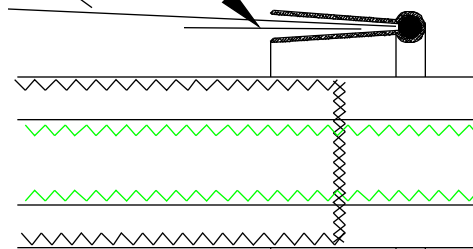

- 3 FOLD THE OVER HANGING BATTEN  
- POCKET TAPE BACK OVER ITSELF, AND SEW SECURLY ALONG THE TOP AND BOTTOM EDGE AS SHOWN.

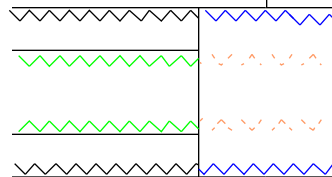

- 4 SEW A GUIDE PAD MADE FROM TIGHT  
- NON-STRETCH WEBBING AROUND 1.5MM THICK TO THE SAIL AS SHOWN. LEAVE APPROX 3/8" BETWEEN THE WEBBING EDGE AND THE BOLT ROPE. HAND WORK THIS ALSO TO SUPPORT ANY MACHINE STITCHING.

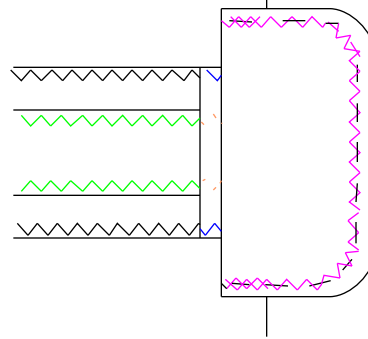

# Leisure furl - SAILMAKING.....Batten End Detail

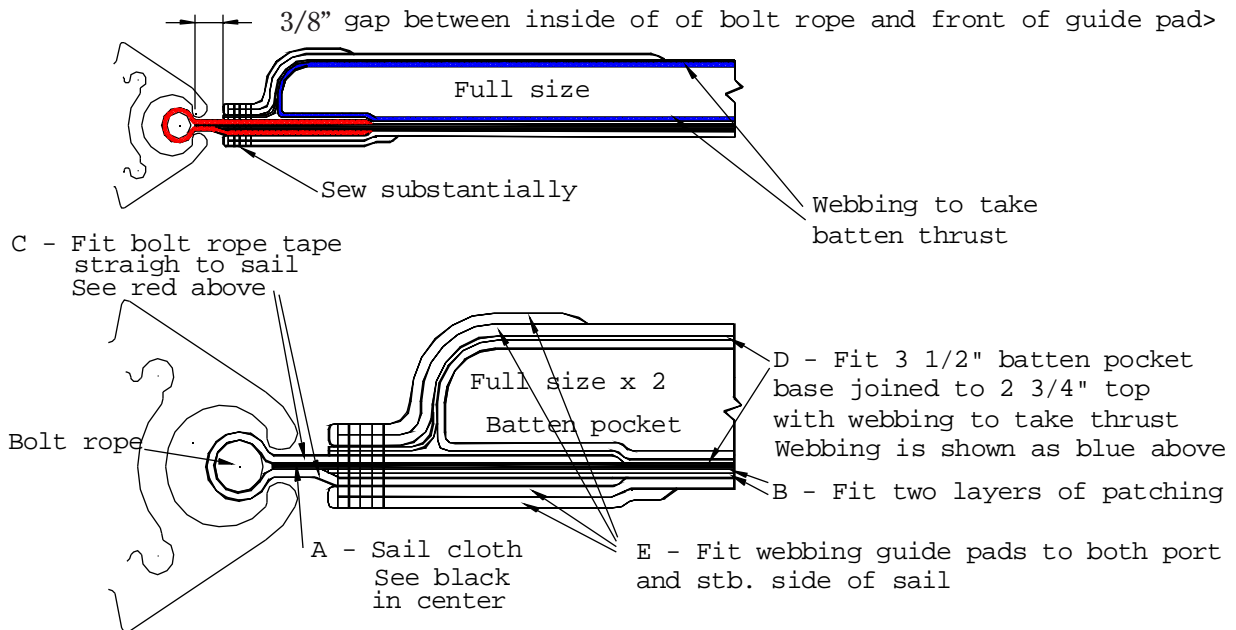
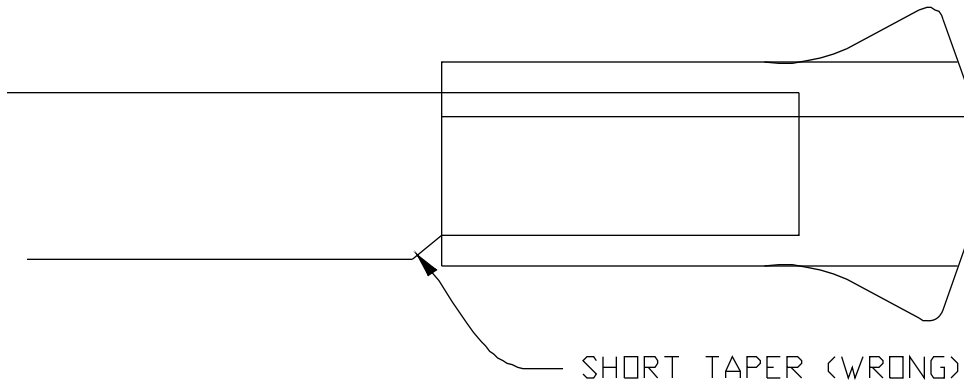
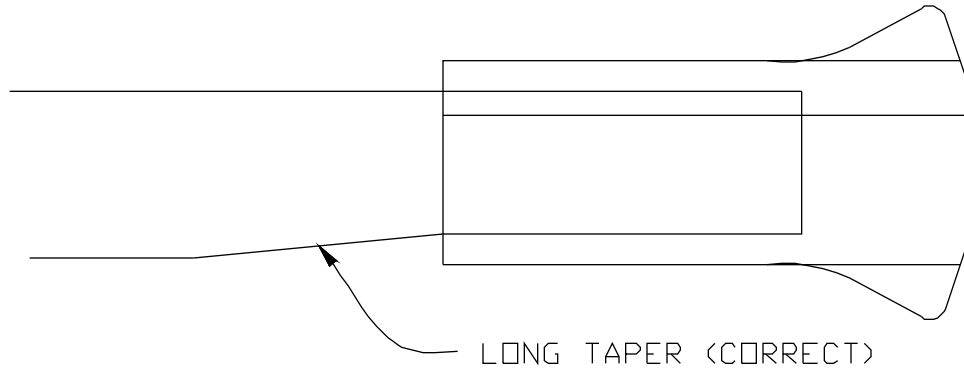

# Leisure furl - SAILMAKING.....Headboard Detail

A conventional ring type head is approved.

**The luff tape should have the boltrope core removed in the top six inches and replaced with the 1/4" diameter polymer rod supplied with luff tape.**

SLUG DETAIL

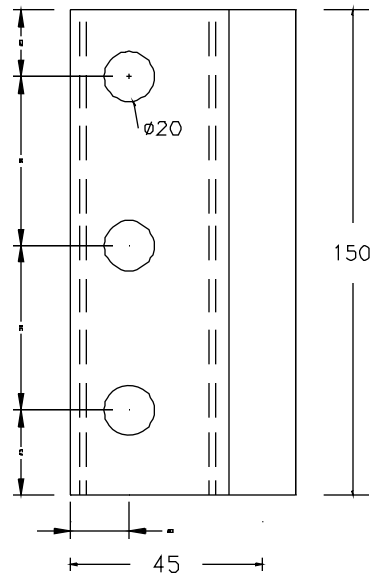
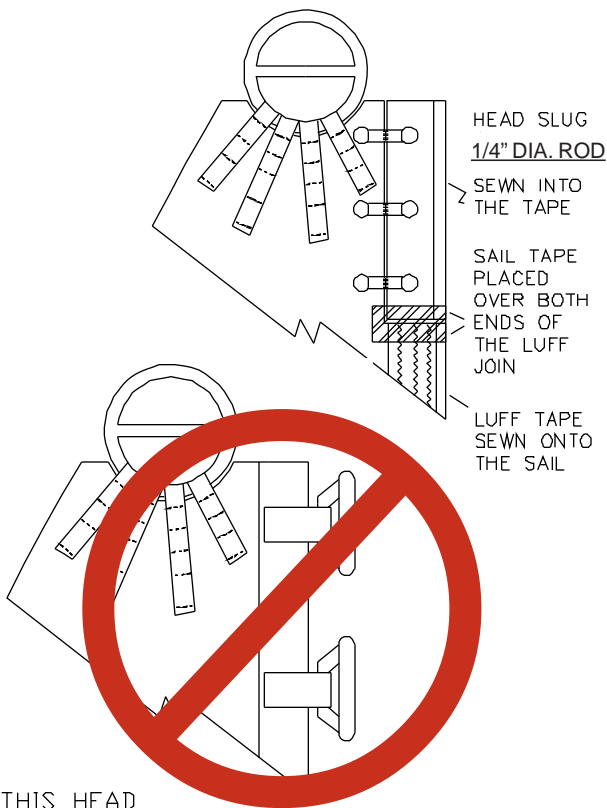
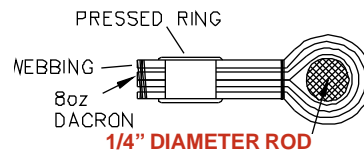

THIS HEAD CONFIGURATION IS NOT SUITABLE WITH LEISURE FURL. DO NOT USE TRACK SLUGS, AS THESE MAY DAMAGE THE TRACK.