

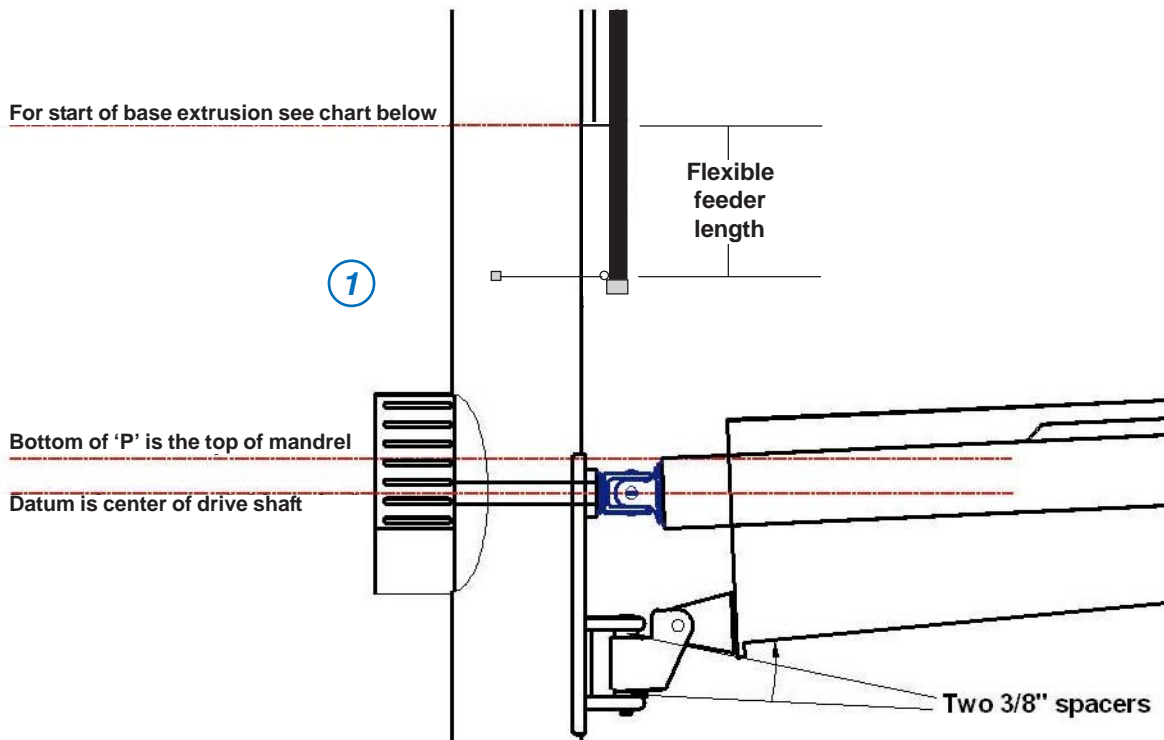

**1) LUFF BASE EXTRUSION AND FLEX FEEDER INSTALLATION CHANGES**

**LUFF BASE EXTRUSION LOWER END RAISED 10" AND FLEX FEEDER LENGTH EXTENDED 10"**

**Putting more FLEX in the Flexible Feeder**



**NEW DIMENSIONS**

System size	Start of base extrusion above datum	Flexible feeder length of sail track
COASTAL	34"	25"
14/5 L	34"	25"
14/5 M	34"	25"
18/6 L	37"	28"
18/6 M	37"	28"
18/6 H	38"	29"
19/6	40"	30"
20/7	42"	30"
25/8	42"	30"
25/8 O/S	42"	30"

**ATTENTION INSTALLERS**

***The installation manuals have been changed***

To increase the ease of movement of the flexible feeder portion of the luff foil we have increased the flexible feeder lengths 10".

This is accomplished by raising the lower end of the luff foil aluminum base extrusion up 10". The stainless steel feeder casting remains in the same location as previous.

Make sure the restrictor line is not too tight.